

Liberty University Trenching & Excavation Safety Program/Policy



PURPOSE & SCOPE

The Environmental Health & Safety Department (EHS) developed this Trenching & Excavation Safety Program/Policy to assure the safety of employees who work in or around trenches and excavations as part of their job duties. It is also designed to protect employees, students, and the general public who work or travel in the vicinity of trenches and excavations. This program/policy complies with the requirements of the Occupational Safety and Health Administration (OSHA) regulations, 29 CFR 1926 (Construction), Subpart P as well as state regulations from Virginia Occupational Safety and Health (VOSH).

This program/policy applies to excavations formed by any man-made cut, cavity, trench, or depression in an earth surface formed by earth removal. There are minimal requirements for excavations less than four feet deep, whereas excavations greater than four feet deep require oversight by a competent person and routine evaluation of hazards and selected controls. Additionally, any activities that may come in contact with buried power, water, sewage, or gas lines requires a competent person on site at all times while operations are performed.

POLICY

Liberty University is committed to providing a safe and healthful work environment for our LU community. It is the policy of Liberty University to take every reasonable precaution to provide a work environment free from recognized hazards for its employees in accordance with the General Duty Clause per the OSHA act Public Law 91-596 Section 5(a)(1) and in accordance with specific OSHA standards.

All employees, students, volunteers, and contractors working under direct LU supervision shall comply with all elements of the LU Trenching & Excavation Safety Program/Policy and with all Federal, State, and Local Regulations.

Additionally, any contractors working independently or through a general contractor on LU properties must comply with the LU Contractor Safety Program found on the EHS website <https://www.liberty.edu/security-public-safety/environmental-health-safety/> under LU Contractor Safety.

APPLICATION, IMPLEMENTATION AND RESPONSIBILITIES

Application

This program/policy applies to all excavation and trenching work on all Liberty University properties or being performed by Liberty University employees regardless of jobsite location.

Responsibility

Supervisors, Department Managers and Department Leadership is responsible for:

- Assuring that all staff at Liberty University who will perform any excavations and/or trenching read and understand this document.
- Assure that any project which they are responsible for, in which excavations and/or trenching operations are taking place that is greater than four feet in depth, or where underground utilities exist within 2 feet of the excavation/trenching area that there is a competent person at the site at all times while work activities are taking place.
- Assure that any personnel conducting trenching and/or excavations have completed the LU Trenching & Excavation Safety Training prior to performing this type of work activity.

Environmental Health & Safety (EHS):

EHS will provide technical support, competent person and awareness level training, and oversight of this program/policy. Involvement by EHS does not relieve the departments, supervisors, or contractors of their individual responsibilities. EHS responsibilities for this program/policy include:

- Developing, implementing, and administering the program/policy.
- Training on all aspects of the program/policy requirements and maintaining centralized records.
- Serving as a technical resource.
- Providing guidance on the selection of protective systems.
- Evaluating the overall effectiveness of the program/policy on a periodic basis and making appropriate changes as needed to assure the safety of personnel.

Employees:

- It is the responsibility of all employees, who work on, in or around excavations to follow the procedures and required paperwork as defined in this program/policy. Attend the required training and wear the appropriate personal protective equipment.

Competent Person:

It is the responsibility of the competent person designated by the department to perform the following tasks once they have received training from EHS.

- Determine the appropriate protective system needed to prevent potential cave-in. Be familiar with protective systems and how to use them.
- Determine the appropriate methods to eliminate or control all hazards including protection from cave-in.
- Conduct site inspections in accordance with the requirements outlined in this program/policy and maintain necessary documentation.
- Ensure employees working in or around or entering trenches or excavations greater than four feet deep have been properly trained before being allowed to perform work activities.
- Have a clear understanding of the procedures for excavating and/or trenching in areas where underground utilities exist and what to do if those utilities are damaged and/or breached.
- Ensure appropriate personal protective equipment is provided and worn.
- Complete the Excavation Permit

Contractors:

Contractors must comply with all local, state, and federal safety requirements, and must assure that all employees performing work on Liberty University property have been suitably trained and are provided appropriate personal protective equipment per the Liberty University Contractor Safety Program. Contractors performing excavation work on university property must coordinate their work with Planning & Construction and/or Facilities Management and VA811 to assure related activities, such as identification, location, and shutdown of utilities are addressed.

Enforcement

Failure to follow the Liberty University Trenching & Excavation Safety Program/Policy can result in life threatening or serious injury situations to staff, facility, students, and visitors. Failure to follow this program/policy can result in disciplinary action up to and including discharge. If contractor's fail to follow required safety standards when doing trenching or excavation work, they may be removed from the Liberty project.

Questions Concerning Policy

Questions concerning this policy should be addressed to Environmental Health and Safety at 434-582-3389 or at lusafety@liberty.edu during normal business hours (7:00 am - 5:00 pm, Monday-Friday).

Applicable Regulations & References

OSHA – 29 CFR 1926, Subpart P.

https://www.osha.gov/Publications/trench_excavation_fs.html

<https://www.osha.gov/Publications/osha2226.pdf>

https://www.osha.gov/sites/default/files/publications/trench_safety_tips_card.pdf

https://www.osha.gov/sites/default/files/publications/trench_excavation_fs.pdf

Training Requirements

Awareness Level Training – Each employee required to work in or around a trench and/or excavation must attend EHS Trenching & Excavation Awareness training prior to being allowed to work in or around a trench and/or excavation. Information regarding related hazards and methods of protection are covered.

Competent Person(s) Level Training – Designated departmental competent persons who will be performing inspections and providing oversight must attend the EHS Trenching & Excavation Competent Person training. Topics include:

- Hazards related to excavation work
- Work practices and selection of protective systems
- Methods of evaluating the site and conducting inspections
- Requirements of this program/policy and any related programs
- How to complete the Excavation Permit
- Emergency procedures

Excavation Permit

Prior to and during an excavation the Liberty University Excavation Permit will have to be completed. This form covers general information about the excavation, preparation for the excavation, hazard control and elimination, PPE being utilized, soil classification, atmospheric testing when required, acceptance of responsibility and authorization and the excavation inspection log. See Appendix A or Environmental Health and Safety Forms on the [EHS Website](#).

Excavation Preparation

1. Pre-plan for all excavation work.
2. VA811 must be contacted (call 811 or 1-800-552-7001) at least 48 hours prior to digging, regardless of the anticipated depth or location to identify sewer, telephone, gas, water line, fiber optic lines, etc. Digging shall not begin until proper clearance has been given as indicated on the ticket.
3. Excavation route must be pre-marked with white paint before utility survey.
4. Determine if a competent person is required on site. Liberty University requires that a competent person be on site at all times during trenching and excavation activities if the location is going to be 4 feet or deeper and employees will be entering the excavation or if employees will be digging within 2 feet on either side of an underground utility.

Excavation Assessment

Prior to entering the excavation, and as necessary throughout the shift, the designated competent person must perform an assessment of the excavation to identify hazardous conditions. This includes any underground or overhead utilities and determine protective measures for personnel entering the excavation, personnel working in the vicinity of the excavation, and the general public, which may be inadvertently exposed to related hazards. This evaluation must be documented.

All hazards identified must be eliminated or controlled prior to personnel entering the excavation. The assessment shall be documented on the LU Excavation Permit.

Excavation Depth

- If excavation is < 4 feet deep or personnel will not be entering, then contacting VA811 to determine if underground utilities are present is the only action required. If this is the case, only sections 1 through 4 are required to be filled out on the excavation permit.
- If between 4 feet and 20 feet, all hazards must be identified and effectively controlled prior to personnel entering the excavation. If this is the case, the entire excavation permit must be completed.
- If > 20 feet, the competent person must contact EHS at 582-3389 for additional review and compliance assurance.
- The Excavation standards do not require a protective system when an excavation is made entirely in stable rock or when an excavation is less than 5 feet (1.52 meters) deep, and a competent person has examined the ground and found no indication of a potential cave-in.

Hazards & Controls

In order to maintain the highest level of safety during trenching & excavation activities the following operating procedures shall be followed:

1. Complete the required forms and a job hazard analysis prior to beginning work.
2. Have a pre-job discussion with all workers to review the work that will be done, the hazards that exists, and the controls and procedures that will be followed to eliminate or minimize those risks.
3. Ensure a means of communication has been established between all employees including those operating heavy machinery.
4. Ensure barricades are in place around the trench or excavation to ensure no one accidentally falls into the excavation.
5. Ensure all equipment that is being utilized is thoroughly inspected daily. Equipment must be inspected prior to use on each shift.
6. Ensure that adequate precautions have been taken for heat and cold stress.
7. Ensure all personnel on site have a clear understanding of emergency procedures and what to do in the event of an emergency.
8. Ensure that proper sloping, benching and/or protective barrier is utilized where applicable.

Cave-In Prevention

Causes: Cave-ins can be caused by the type of soil, adjoining buildings or walls or other structures and equipment.

Primary means of cave-in prevention:

- Sloping and benching the sides of the excavation
- Supporting the sides of the excavation
- Placing a shield between the side of the excavation and the work area

In many cases, the type of protective system needed is well known and simple to use. At other times, it will undertake a more complex process of designing a protective system. Designing a protective system requires consideration of many factors, including soil classification, depth of cut, water content of soil, weather and climate, and other operations in the

vicinity. If a design system needs to be utilized, it must be coordinated through the Environmental Health & Safety department.

Some examples of protective systems for cave-in protection include:

Sloping the sides of the excavation to an angle not steeper than 1½:1 (for every foot of depth, the trench must be excavated back 1½ feet). A slope of this gradation is safe for any type of soil.

Slope of 1½:1

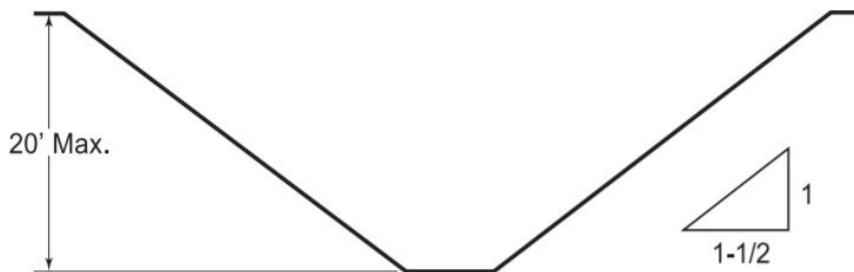

Excavation Safety: Protective Systems

General Information

Each employee in an excavation shall be protected from cave-in by using either an adequate sloping/benching system or an adequate support/protective system.

Exceptions to this requirement are limited to:

- Excavations made in stable rock.
 - Note: “Stable Rock” is not recognized by Virginia Occupational Safety and Health (VOSH) in the Commonwealth of Virginia and should not be considered as an option.
- Excavations less than five feet in depth where examination of the ground by a Competent Person provides no indication of a potential cave-in.

Protective systems shall be capable of resisting all loads that could be reasonably expected to be applied to the system.

Sloping & Benching

Sloping and benching system requirements are specified below for excavations between four and twenty feet deep. The angle of the slope or bench is determined by the class of soil present at the excavation site.

- **Best Practice:** The competent person may assume the worst class of soil (i.e., the most unstable), class “C,” and angle the sides of the excavations 34° (2 ½ H to 1 V).
- If the competent person has classified the soil and determined that it is class “B,” the angle of the sides of the excavation must be 45° (1 H to 1 V).
- If the competent person has classified the soil and determined that it is class “A,” the angle of the sides of the excavation must be 53° (3/4 H to 1 V).

Personnel shall not be permitted to work above other personnel on the faces of sloped or benched protective systems except when personnel at lower levels are protected from the hazards of falling, rolling, or sliding materials or equipment.

Sloping

Maximum allowable slopes for excavations less than 20 feet (6.09m) based on soil type and angle to the horizontal as follows:

Allowable Slopes

Soil Type	Height to Depth Ratio	Slope Angle
Stable Rock	Vertical	90°
Type A	3/4:1	53°
Type B	1:1	45°
Type C	1 1/2 :1	34°
Type A (short term)	1/2:1	63°

For a maximum excavation depth of 12 feet.

Figure: Slope Configurations: Excavations in Layered Soils

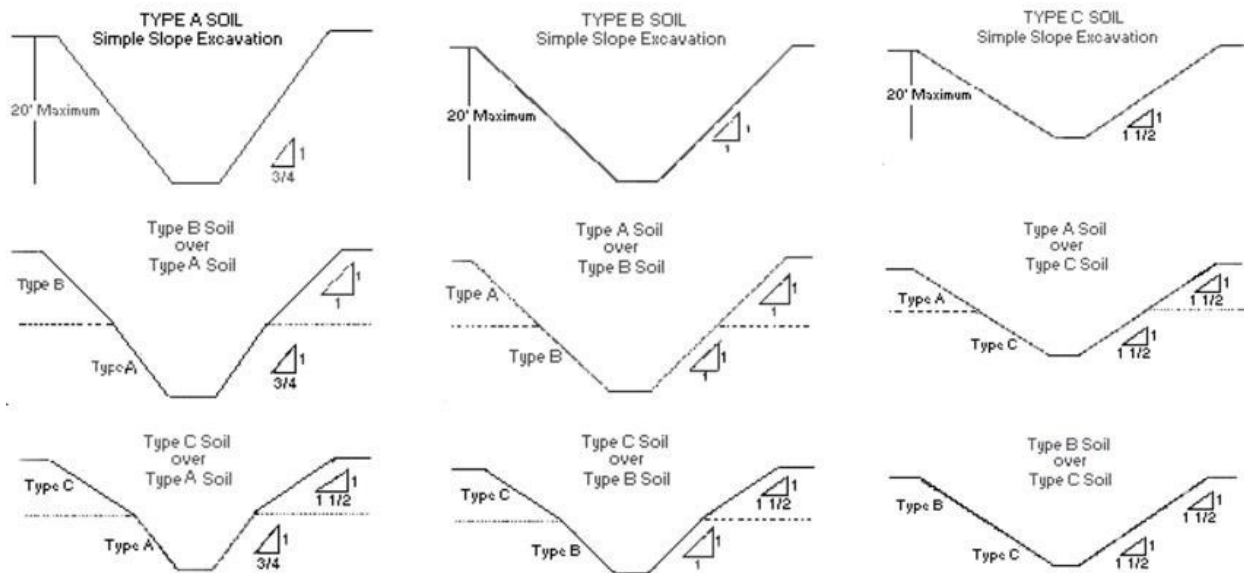
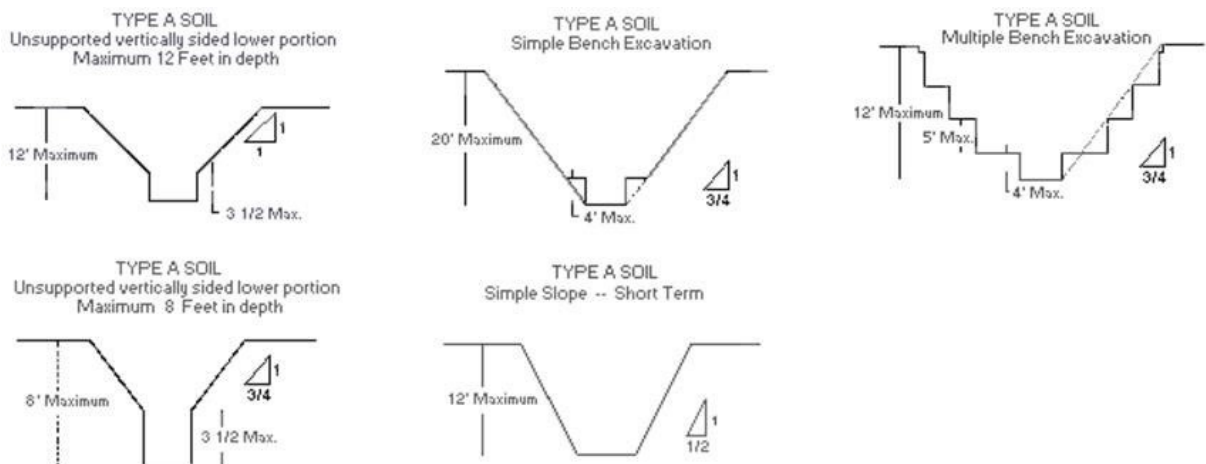

Figure: Excavations Made in Type A Soil



Benching

There are two basic types of benching, simple and multiple. The type of soil determines the horizontal to vertical ratio of the benched side.

As a general rule, the bottom vertical height of the trench must not exceed 4 ft. (1.2 m) for the first bench. Subsequent benches may be up to a maximum of 5 ft. (1.5 m) vertical in Type A soil and 4 ft. (1.2 m) in Type B soil to a total trench depth of 20 ft. (6.0 m). All subsequent benches must be below the maximum allowable slope for that soil type. For Type B soil, the trench excavation is permitted in cohesive soil only.

Figure: Excavations Made in Type B Soil

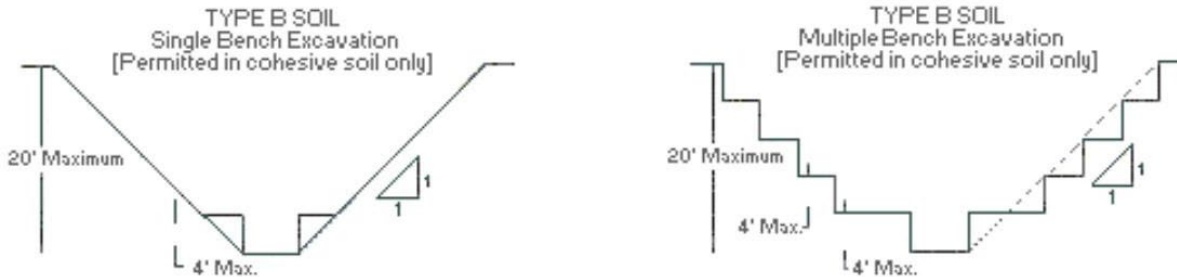

SPOILS

Temporary Spoil

Temporary spoil must be placed no closer than 2 ft. (0.61 m) from the surface edge of the excavation, measured from the nearest base of the spoil to the cut. This distance should not be measured from the crown of the spoil deposit. This distance requirement ensures that loose rock or soil from the temporary spoil will not fall on employees in the trench.

Spoil should be placed so that it channels rainwater and other run-off water away from the excavation. Spoil should be placed so that it cannot accidentally run, slide, or fall back into the excavation.

Figure: Temporary Spoil

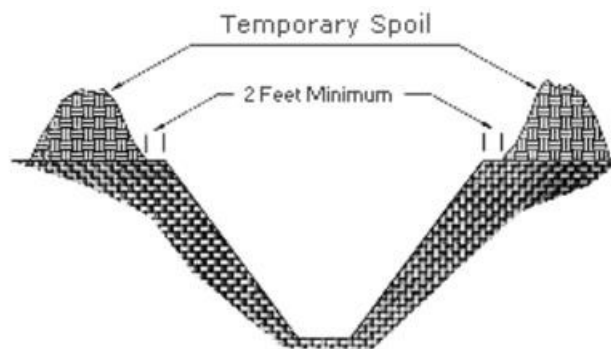

Permanent Spoil

Permanent spoil should be placed at some distance from the excavation. Permanent spoil is often created where underpasses are built, or utilities are buried. The improper placement of permanent spoil, i.e., insufficient distance from the working excavation, can cause an excavation to be out of compliance with the horizontal-to-vertical ratio requirement

for a particular excavation. This can usually be determined through visual observation. Permanent spoil can change undisturbed soil to disturbed soil and dramatically alter slope requirements.

TRENCH BOXES (BEST PRACTICE)

Trench boxes are pre-built systems designed to manufacturer's tabulated data. These boxes must be used in accordance with all specifications, recommendations, and limitations issued or made by the manufacturer. Trench boxes are different from shoring because, instead of shoring up or otherwise supporting the trench face, they are intended primarily to protect workers from cave-ins and similar incidents. The excavated area between the outside of the trench box and the face of the trench should be as small as possible. The space between the trench boxes and the excavation side are backfilled to prevent lateral movement of the box. Shields may not be subjected to loads exceeding those, which the system was designed to withstand.

- Trench boxes must not be used at a depth greater than that for which they were designed.
- The shield must be installed in a safe manner to restrict lateral or other hazardous movement of the shield in the event of a sudden cave-in. The closer a properly constructed trench shield/box is to the trench wall, the less chance that it could be dislodged by a lateral force.
- Personnel shall not be allowed in trench boxes when they are being installed, removed, or moved vertically/horizontally (where hazardous).
- Personnel shall not work outside of the protective structure of the trench box where protective systems are not provided.

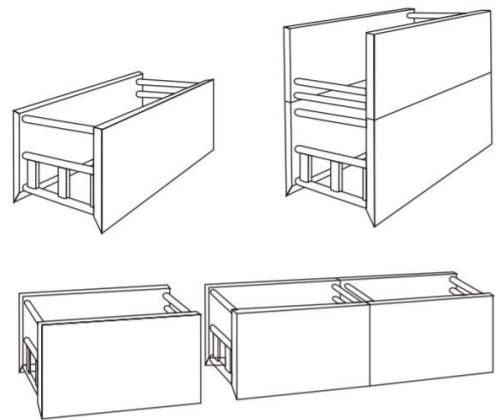

Where preassembled shield systems or sloping/benching is not available or feasible, the competent person must implement an appropriate system designed to OSHA criteria (i.e., timber or aluminum hydraulic shoring), or have written approval by a registered professional engineer to implement the system designed by him/her.

For more information on timber shoring or aluminum hydraulic shoring, visit the [OSHA website](#).

Shoring Types

Shoring is the provision of a support system for trench faces used to prevent movement of soil, underground utilities, roadways, and foundations. Shoring or shielding is used when the location or depth of the cut makes sloping back to the maximum allowable slope impractical. Shoring systems consist of posts, Wales, struts, and sheeting. There are two basic types of shoring, timber, and aluminum hydraulic.

Figure: Timber Shoring

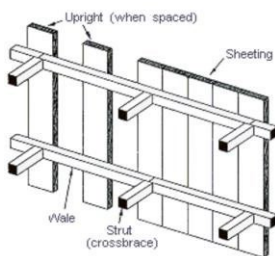

Hydraulic Shoring

The trend today is toward the use of hydraulic shoring, a prefabricated strut and/or wale system manufactured of aluminum or steel. Hydraulic shoring provides a critical safety advantage over timber shoring because workers do not have to enter the trench to install or remove hydraulic shoring. Other advantages of most hydraulic systems are that they:

- Are light enough to be installed by one worker.
- Are gauge-regulated to ensure even distribution of pressure along the trench line.
- Can have their trench faces "preloaded" to use the soil's natural cohesion to prevent movement; and
- Can be adapted easily to various trench depths and widths.

All shoring should be installed from the top down and removed from the bottom up. Hydraulic shoring should be checked at least once per shift for leaking hoses and/or cylinders, broken connections, cracked nipples, bent bases, and any other damaged or defective parts.

Figure: Shoring Variations: Typical Aluminum Hydraulic Shoring Installations

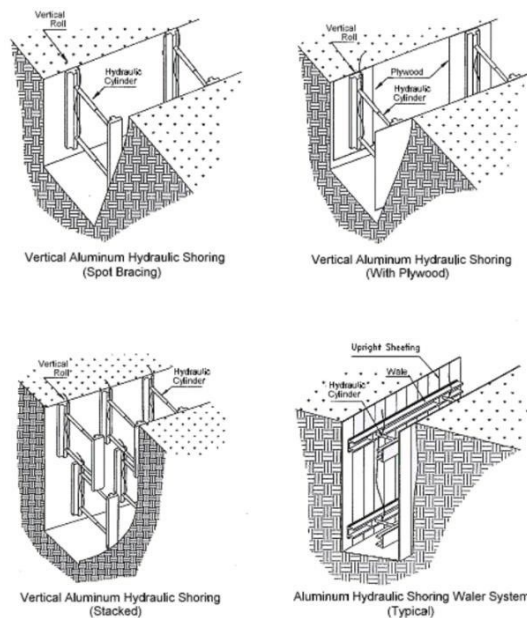

EXCAVATIONS GREATER THAN 20 FEET

Excavations that are greater than 20 feet must be designed or approved by an engineer. Designing a sloping and benching system in accordance with tabulated data, such as tables and charts must be signed off by a registered professional engineer. This data must be in writing and must include enough explanatory information (including the criteria for selecting a system and the limits on the use of the data) for the user to be able to select an appropriate protective system. At least one copy of the data, which identifies the registered professional engineer who approved it, must be kept at the worksite during construction of the protective system. After the system is completed, the data may be stored away from the jobsite, but a copy must be provided upon request to an OSHA compliance officer. Additionally, a copy must be provided to the EHS department.

Other Means of Cave-in Protection

- Pneumatic Shoring
- Bracing
- Underpinning

Pneumatic Shoring

Works in a manner similar to hydraulic shoring. The primary difference is that pneumatic shoring uses air pressure in place of hydraulic pressure. A disadvantage to the use of pneumatic shoring is that an air compressor must be on site.

1. **Screw Jacks.** Screw jack systems differ from hydraulic and pneumatic systems in that the struts of a screw jack system must be adjusted manually. This creates a hazard because the worker is required to be in the trench in order to adjust the strut. In addition, uniform "preloading" cannot be achieved with screw jacks, and their weight creates handling difficulties.
2. **Single-Cylinder Hydraulic Shores.** Shores of this type are generally used in a water system, as an assist to timber shoring systems, and in shallow trenches where face stability is required.
3. **Underpinning.** This process involves stabilizing adjacent structures, foundations, and other intrusions that may have an impact on the excavation. As the term indicates, underpinning is a procedure in which the foundation is physically reinforced. Underpinning should be conducted only under the direction and with the approval of a registered professional engineer.

Figure: Shoring Variations

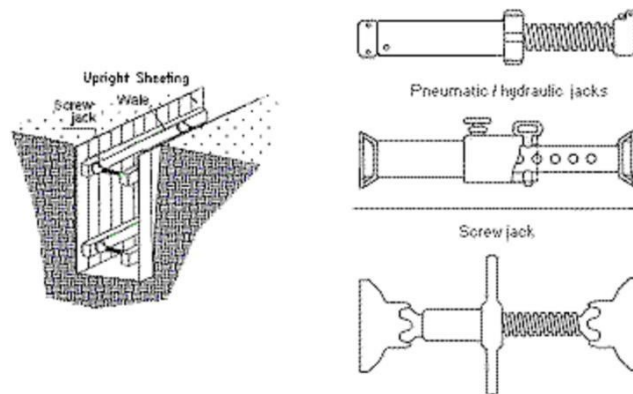

Excavation Safety: Soil Mechanics & Classification

Soil Mechanics

A number of stresses and deformations can occur in an open cut or trench. For example, increases or decreases in moisture content can adversely affect the stability of a trench or excavation. The following diagrams show some of the more frequently identified causes of trench failure.

Tension Cracks. Tension cracks usually form at a horizontal distance of 0.5 to 0.75 times the depth of the trench, measured from the top of the vertical face of the trench. See the accompanying drawing for additional details.

Figure: Tension Crack

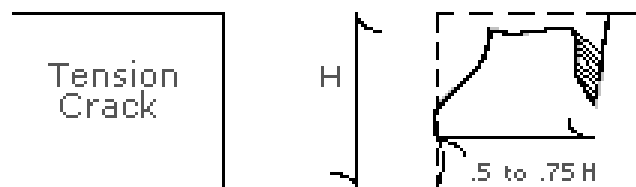

Sliding or sluffing may occur as a result of tension cracks, as illustrated below.

Figure: Sliding

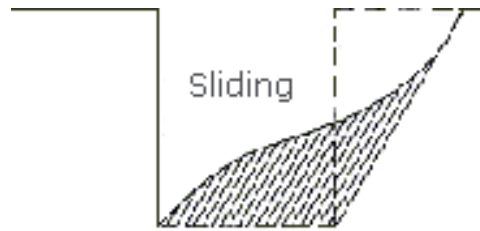

Toppling. In addition to sliding, tension cracks can cause toppling. Toppling occurs when the trench's vertical face shears along the tension crack line and topples into the excavation.

Figure: Toppling

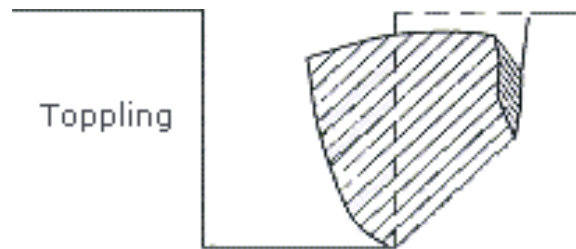

Subsidence and Bulging. An unsupported excavation can create an unbalanced stress in the soil, which, in turn, causes subsidence at the surface and bulging of the vertical face of the trench. If uncorrected, this condition can cause face failure and entrapment of workers in the trench.

Figure: Subsidence and Bulging

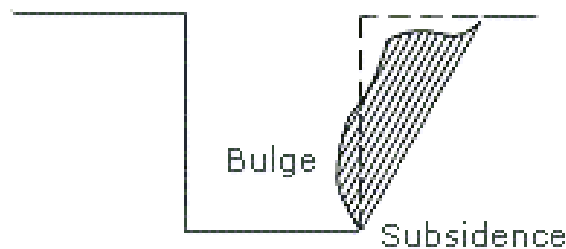

Heaving or squeezing. Bottom heaving or squeezing is caused by the downward pressure created by the weight of adjoining soil. This pressure causes a bulge in the bottom of the cut, as illustrated in the drawing above. Heaving and squeezing can occur even when shoring or shielding has been properly installed.

Figure: Heaving or Squeezing

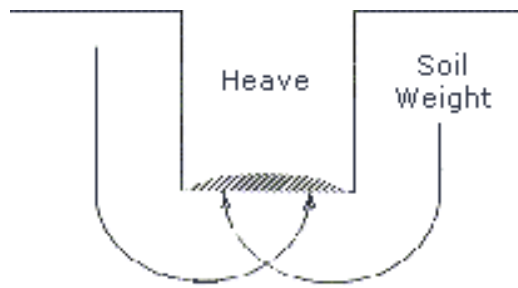

Boiling is evidenced by an upward water flow into the bottom of the cut. A high-water table is one of the causes of boiling. Boiling produces a "quick" condition in the bottom of the cut and can occur even when shoring or trench boxes are used.

Figure: Boiling

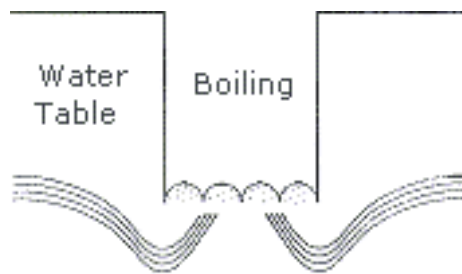

Unit Weight of Soils refers to the weight of one unit of a particular soil. The weight of soil varies with type and moisture content. One cubic foot of soil can weigh from 110 pounds to 140 pounds or more, and one cubic meter (35.3 cubic feet) of soil can weigh more than 3,000 pounds.

Soil Classification

Methods of classifying soil and rock deposits based on site and environmental conditions, and on the structure and composition of the earth deposits, is provided here.

Soil must be classified by a competent person whenever a 34-degree angle (i.e., 1 ½ H to 1 V) cannot be achieved for sloping or benching, whenever timber or aluminum hydraulic shoring will be used, or if other protective systems are used that will be designed by a registered professional engineer and implemented. All protective systems used shall comply with 29 CFR 1926, Subpart P.

Each soil and rock deposit shall be classified by a competent person in accordance with the criteria described for each class of soil. Classes of soil include:

- Stable rock (not recognized in Virginia as an acceptable soil class),
- Class "A"
- Class "B,"
- Class "C." When class "C" soil is chosen or assumed, the methods of classifying soil described in this section do not have to be performed.

Soil Classification Definitions

Class A: Type A soil is cohesive and has a high unconfined compressive strength; 1.5 tons per square foot or greater. Examples of Type A soil include clay, silty clay, sandy clay, and clay loam. Soil cannot be classified as Type A if it is fissured, if it has been previously disturbed, if it has water seeping through it, or if it is subject to vibration from sources

Type B soil is cohesive and has often been cracked or disturbed, with pieces that don't stick together as well as Type A soil. Type B soil has medium unconfined compressive strength; between 0.5 and 1.5 tons per square foot. Examples of Type B soil include angular gravel, silt, silt loam, and soils that are fissured or near sources of vibration, but could otherwise be Type A.

Type C soil is the least stable type of soil. Type C includes granular soils in which particles don't stick together and cohesive soils with a low unconfined compressive strength; 0.5 tons per square foot or less. Examples of Type C soil include gravel, and sand. Because it is not stable, soil with water seeping through it is also automatically classified as Type C soil, regardless of its other characteristics.

Basis of classification

The classification of the deposits shall be made based on the results of at least one visual and at least one manual analysis. Such analyses shall be conducted by a competent person using tests described below, or in other recognized methods of soil classification and testing such as those adopted by the American Society for Testing Materials, or the U.S. Department of Agriculture textural classification system.

Visual and Manual Analyses

The visual and manual analyses, such as those noted here, shall be conducted to provide sufficient quantitative and qualitative information as may be necessary to identify the properties, factors, and conditions affecting the classification of the deposits.

Layered Systems

In a layered system, the system shall be classified in accordance with its weakest layer. However, each layer may be classified individually where a most stable layer lies under a less stable layer.

Reclassification

If, after classifying a deposit, the properties, factors, or conditions affecting its classification change in any way, a competent person shall evaluate the changes. The deposit shall be reclassified as necessary to reflect the changed circumstances.

Visual Tests

Visual analysis is conducted to determine qualitative information regarding the excavation site in general, the soil adjacent to the excavation, the soil forming the sides of the open excavation, and the soil taken as samples from excavated material.

- Observe samples of soil that are excavated and soil in the sides of the excavation. Estimate the range of particle sizes and the relative amounts of the particle sizes. Soil that is primarily composed of fine-grained material is cohesive material. Soil composed primarily of coarse-grained sand or gravel is granular material.
- Observe soil as it is excavated. Soil that remains in clumps when excavated is cohesive. Soil that breaks up easily and does not stay in clumps is granular.
- Observe the side of the opened excavation and the surface area adjacent to the excavation. Crack-like openings such as tension cracks could indicate fissured material. If chunks of soil spall off a vertical side, the soil could be fissured. Small spalls are evidence of moving ground and are indications of potentially hazardous situations.

- Observe the area adjacent to the excavation and the excavation itself for evidence of existing utility and other underground structures and identify previously disturbed soil.
- Observe the opened side of the excavation to identify layered systems. Examine layered systems to identify if the layers slope toward the excavation. Estimate the degree of slope of the layers.
- Observe the area adjacent to the excavation and the sides of the opened excavation for evidence of surface water, water seeping from the sides of the excavation, or the location of the level of the water table.
- Observe the area adjacent to the excavation and the area within the excavation for sources of vibration that may affect the stability of the excavation face.

Manual Tests

Manual analysis of soil samples is conducted to determine quantitative as well as qualitative properties of soil and to provide more information in order to classify soil properly.

Plasticity – Mold a moist or wet sample of soil into a ball and attempt to roll it into threads as thin as 1/8-inch in diameter. Cohesive material can be successfully rolled into threads without crumbling. For example, if at least a two-inch (50 mm) length of 1/8-inch thread can be held on one end without tearing, the soil is cohesive.

Dry Strength – If the soil is dry and crumbles on its own or with moderate pressure into individual grains or fine powder, it is granular (any combination of gravel, sand, or silt). If the soil is dry and falls into clumps, which breaks up into smaller clumps, but the smaller clumps can only be broken up with difficulty, it may be clay in any combination with gravel, sand, or silt. If the dry soil breaks into clumps which do not break up into small clumps and which can only be broken with difficulty, and there is not visual indication the soil is fissured, the soil may be considered un-fissured.

Thumb penetration - The thumb penetration test can be used to estimate the unconfined compressive strength of cohesive soils. (Based on the thumb penetration test described in American Society for Testing and Materials (ASTM) Standard designation D2488 – “Standard Recommended Practice for Description of Soils (Visual – Manual Procedure).”) Type A soils with an unconfined compressive strength of 1.5 TSF can be readily indented by the thumb; however, they can be penetrated by the thumb only with very great effort. Type C soils with an un-confined compressive strength of 0.5 TSF can be easily penetrated several inches by the thumb and can be molded by light finger pressure. This test should be conducted on an undisturbed soil sample, such as a large clump of soil, as soon as practical after excavation to keep to a minimum the effects of exposure to drying influences. If the excavation is later exposed to wetting influences (rain, flooding), the classification of the soil must be changed accordingly.

Other Strength tests – Estimates of unconfined compressive strength of soils can also be obtained by use of a pocket penetrometer or by using a hand operated shear vane.

Drying Test – The basic purpose of the drying test is to differentiate between cohesive material with fissures, un-fissured cohesive material, and granular material. The procedure for the drying test involves drying a sample of soil that is approximately one inch thick (2.54 cm) and six inches (15.24 cm) in diameter until it is thoroughly dry:

- If the sample develops cracks as it dries, significant fissures are indicated.
- Samples that dry without cracking are to be broken by hand. If considerable force is necessary to break a sample, the soil has significant cohesive material content. The soil can be classified as an un-fissured cohesive material and the unconfined compressive strength should be determined.
- If a sample breaks easily by hand, it is either a fissured cohesive material or a granular material. To distinguish between the two, pulverize the dried clumps of the sample by hand or by stepping on them. If the clumps do not pulverize easily, the material is cohesive with fissures. If they pulverize easily into very small fragments, the material is granular.

Protection Against Other Hazards

- **Surface Encumbrances:** All equipment, materials, supplies, permanent installations (e.g., buildings, roadways, sidewalks, trees, boulders, etc.) at the surface of the excavation that should present a hazard to personnel working in the excavation must be removed or supported, as necessary.
- **Underground Installations:** Arrangements must be made, as necessary, by the competent person with the appropriate utility agency for the protection, removal, shutdown/de-energized, or relocation of underground installations identified by VA811.
 - Work on such installations shall only be conducted by authorized personnel (i.e., the owner of the installation).
 - If it is not possible to establish the exact location of underground installations, the work may proceed with caution utilizing **only hand digging** to locate the utility as the excavation is opened and each underground **installation** is approached.
- **Access/Egress:** Stairs, ladders, or ramps must be provided where personnel must enter excavations four feet or more in depth and must comply with OSHA rules and regulations. **The maximum distance of travel** in an excavation to a means of egress **shall not exceed 25 feet**. Ladders must be secured and extend a minimum of 36 inches (0.9 m) above the landing.
- **Vehicular Traffic:** Excavations affecting vehicular traffic must be barricaded and warnings provided to oncoming traffic. Additional precautions include high visibility warning vests and flaggers as needed. Personnel designated to flag traffic must comply with the Virginia Department of Transportation's flagger certification program.
- **Falling Loads:** Personnel **shall not be permitted underneath loads** handled by lifting or digging equipment. All personnel are required to stand away from any vehicle loaded or unloaded. **Vehicle operators may remain in the cab of the vehicle being loaded or unloaded by lifting/digging equipment provided the vehicle cab is reinforced or otherwise adequately protected from impact.**
- **Mobile Equipment:** When mobile equipment is operated adjacent to the edge of an excavation, a warning system must be used when the operator does not have a clear and direct view of the edge of the excavation. The warning system may consist of barricades, hand or mechanical signals, signs/flags, or stop logs. If possible, the surface grade should be sloped away from the excavation.
- **Hazardous Atmosphere:** Atmospheric testing must be conducted in excavations over four feet deep where a hazardous atmosphere could reasonably be expected to exist, such as near landfill areas, near hazardous substance storage, near gas pipelines, or whenever, hazardous chemicals will be used in the excavation. This determination is made by the competent person during excavation evaluation and/or inspection.
 - Emergency rescue equipment, such as breathing apparatus, safety harness and lifeline, or basket stretcher shall be readily available where hazardous atmospheric conditions exist or may reasonably be expected to develop during work in an excavation. This equipment shall be attended when in use. ******* STOP! If this condition exists, stop all work activities, and contact EHS.** If hazardous atmospheric conditions are identified all work must cease until the source can be abated. If abatement is not possible, a contractor that is trained and equipped to work in hazardous environments will be utilized to complete the work.
- **Water Accumulation:** Personnel are not permitted to work in excavations that contain or are accumulating water unless precautions have been taken to protect personnel from hazards posed by water accumulation. These

precautions may include special support or shield systems to protect from cave-in, water removal by mechanical pump to control the level of water accumulation, or the use of a safety harness and lifeline.

- If water is controlled or prevented from accumulating by the use of water removal equipment, the equipment and operation must be monitored by a person familiar with the equipment.
 - If excavation work will interrupt the natural drainage of surface water (e.g., streams), diversion ditches, dikes, or other suitable means must be used to prevent surface water from entering the excavation. Precautions must also be taken to provide adequate drainage of the area adjacent to the excavation.
 - Excavations subject to runoff from heavy rains must be re-inspected by the competent person to determine if additional precautions are necessary.
- **Adjacent Structures:** Where the stability of adjoining buildings, walls, or other structures may be endangered by excavation operations, support systems (i.e., shoring, bracing, or underpinning) shall be provided to ensure the stability of the structure and provide adequate personnel protection. Excavations below the level of a base or footing of any foundation or retaining wall that could reasonably be expected to pose a hazard to personnel is not permitted unless:
 - A support system, such as underpinning, is provided to ensure the safety of personnel and the stability of the structure; or
 - A registered professional engineer has approved the determination that the structure is sufficiently removed from the excavation so as to be unaffected by the excavation activity; or
 - A registered professional engineer has approved the determination that such excavation work will not pose a hazard to employees.
 - Note: Where review or approval of a support system by a registered professional engineer is required, the competent person shall secure this in writing before work begins. A copy of this approval must be provided to EHS upon request.
- **Loose Rock or Soil:** Adequate protection must be provided to protect employees from loose rock, soil, or other materials that could pose a hazard by falling or rolling from an excavation face. Such protection may consist of:
 - Scaling to remove loose material.
 - Installation of protective barriers, such as wire mesh or timber on the face of the slope, at appropriate intervals, to stop and contain falling material,
 - Sufficient benching to contain falling material,
 - Keeping materials or equipment at least two feet from the edge of the excavation,
 - Use of restraining devices that are sufficient to prevent materials or equipment from falling or rolling into the excavation.
- **Fall Protection:** Standard guardrails, fences, or barricades must be provided for excavations adjacent to walkways, driveways, and other pedestrian or vehicle thoroughfares. Walkways or bridges for public and site personnel to cross over excavations must be provided when the excavation width is greater than 30 inches, and depth is greater than four feet. Walkways and bridges must have standard guardrails and be at least 19 inches in width. If the walkway will serve the general public, it must be at least 36 inches in width, or the width of the building exit door(s) if serving as the exit for that building, whichever is greater. Where personnel will be working or passing under such walkways, a toe-board must be installed on the walkway. Wells, holes, pits, shafts, and similar excavations must be effectively barricaded or covered and posted (as necessary) to prevent unauthorized access. All temporary excavations of this type must be backfilled as soon as possible.
- **Security:** When an excavation will be left open overnight, barricades and/or fencing to restrict access, warning signs, and adequate lighting shall be provided as necessary to protect the public.

- **Personal Protective Equipment (PPE):** Indicate the minimum personal protective equipment, associated with excavation hazards, required for entry into the excavation.

Entry Authorization

- **Competent Person:** Once the competent person has evaluated the site conditions and necessary control measures have been implemented, the competent person shall sign the Excavation Permit and post it at the entrance of the excavation, or other central location. Personnel shall not enter the excavation until the permit has been completed, control measures implemented, and entry has been authorized on the form. All entrants must review the information provided on the excavation permit so that hazards are known, and protective measures understood. If any of the controls identified on the permit have been altered, removed, or damaged, entry should not occur until the competent person has re-evaluated the situations and corrective measures have been taken.
- **In case of emergency:** Contact 911 or Liberty University Police Department (LUPD) at 434-592-3911 immediately! Personnel shall have a means of contacting emergency services in the event of an emergency.

Excavation Safety Inspections

Inspections

The departmental competent person shall conduct daily inspections of excavations, adjacent areas, and protective systems for evidence of a situation that could result in possible cave-ins, failure of protective systems, hazardous atmospheres, or other hazardous conditions. Daily inspections **must be conducted** by the competent person **prior to the start of work and at shift changes** each day. Additionally, inspections shall be done as needed throughout the shift. Inspections are especially critical on Mondays, where rain or other changing conditions occurring over the weekend may have deteriorated soil conditions and/or protective systems. If personnel will not be entering the excavation on a given day, inspection is not required. Items to inspect include:

- Surface conditions
 - No cracks along the top edge of the excavation
 - Spoil piles, materials, and equipment are not within two feet of the edge of excavation
 - No standing water in the excavation
 - No sources of vibration
- Banks and Sides of Slope/Bench
 - No cracks on the walls of the excavation
 - No spalling (i.e., soil falling from the sides of the excavation into the excavation)
 - No changes in soil type
 - Slope remains adequate for the class of soil originally selected
- Shoring/Shielding
 - Shoring/shielding still in place and effective
 - Hydraulic cylinders not leaking
 - Wedges remain tight

- Access/Egress
 - Stairs, ladders, or ramps for access/egress in place and secured, where applicable)
- Existing Utilities
 - Utilities identified and protected
 - Utilities de-energized or shut off, where necessary
 - Support is adequate
- Weather
 - No overnight freezing/thawing
 - No overnight rain (heavy)

Additional Inspections

Inspections shall also be made after each hazard-changing event, such as heavy rains and appropriate corrective measures taken where necessary. Where the competent person, or personnel entering the excavation, find evidence of a situation that could result in a possible cave-in, protective system failure, hazardous atmospheric conditions, or other hazardous conditions exposed personnel shall evacuate the excavation until the situation has been evaluated and corrected.

Documentation

The competent person shall maintain written documentation of the inspections on the Excavation Permit, Section 8, Excavation Inspection Log of all inspections conducted. This log shall include the inspectors name, signature, date and time of the inspection, weather conditions, general conditions, hazards identified, and corrective action taken if needed. If more than, three inspections are required for that day/shift, then utilize notebook paper including all the above information as well as site location and attach to the Excavation Permit.

Excavation Emergencies

A typical trench collapse involves three to five cubic yards of soil, or about 6,000 to 20,000 pounds! Hazardous effects include compression and asphyxiation. Typical extraction can take one to seven hours depending on the conditions of the cave in. Individuals should not place themselves at risk in order to save the life of another. Such situations too often lead to the death of the would-be rescuer as well as the person originally in danger. It is the intent of this program to minimize the associated risks with excavation work and focus on accident prevention.

Lynchburg Fire Department or Campbell County Fire Department is the designated response agency for cave in emergencies depending on the location of the work site. Other emergency agencies may be the responders for off campus facilities. Be sure you know who the emergency response agency is for the area in which you are working prior to beginning work. The first and most important action that can be taken in the event of a cave in is to activate the emergency response system by contacting 911 or Liberty University Police Department (LUPD) at 434-592-3911 immediately!

Personnel at Liberty University are not trained, nor expected, to perform trench rescue. However, several actions can be taken to support the rescue team and further protect on site personnel.

- If victim is not visible, try to identify the area where the victim most likely is located as closely as possible.
- Hand digging, if it is safe to approach the site, begin immediately.

➤ **Mechanical excavating equipment should not be used to dig the person out due to potential for additional injury, crushing, or dismemberment.**

- Have someone meet the fire department upon their arrival and brief them on the situation.
- Assemble materials and equipment that may be beneficial during rescue operations, such as shovels, plywood/lumber, ladders, buckets, etc.
- Clear the area so that rescue personnel have access to the site.

Excavation Definitions

Accepted Engineering Practices means the standards of practice required by a registered professional engineer.

Adjacent Structure Stability refers to the stability of the foundation of adjacent structures whose location may create surcharges, changes in soil conditions, or other disruptions that have the potential to extend into the failure zone of the excavation.

Aluminum Hydraulic Shoring means a manufactured shoring system consisting of aluminum hydraulic cylinders (cross braces) used with vertical rails (uprights) or horizontal rails (wales). Such system is designed to support the sidewalls of an excavation and prevent cave-ins.

Bell-bottom Pier Hole means a type of shaft or footing excavation, the bottom of which is made larger than the cross section above to form a belled shape.

Benching or Benching System is a method of protecting employees from cave-ins by excavating the sides of an excavation to form one or more horizontal steps, usually with vertical or near-vertical surfaces between levels.

Cave-in means the movement of soil or rock into an excavation, or the loss of soil from under a trench shield or support system, in amounts large enough to trap, bury, or injure and immobilize a person.

Cemented soil means a soil in which the particles are held together by a chemical agent, such as calcium carbonate, such that a hand-size sample cannot be crushed into powder or individual soil particles by finger pressure.

Class "A" soil means cohesive soils with an unconfined, compressive strength of 1.5 ton per square foot (TSF) (144 kPa) or greater. Examples of cohesive soils are clay, silty clay, sandy clay, clay loam and, in some cases, silty clay loam and sandy clay loam. Cemented soils such as caliche and hardpan are also considered Type A. However, no soil is Type A if:

- The soil is fissured; or
- The soil is subject to vibration from heavy traffic, pile driving, or similar effects; or
- The soil has been previously disturbed; or
- The soil is part of a sloped, layered system where the layers dip into the excavation on a slope of four horizontal to one vertical (4H:1V) or greater; or
- The material is subject to other factors that would require it to be classified as a less stable material.

Class "B" soil means:

- Cohesive soil with an unconfined compressive strength greater than 0.5 TSF (48 kPa) but less than 1.5 TSF (144 kPa); or
- Granular cohesion less soils including angular gravel (similar to crushed rock), silt, silt loam, sandy loam and, in some cases, silty clay loam and sandy clay loam.

- Previously disturbed soils except those, which would otherwise be classified as Type C soil.
- Soil that meets the unconfined compressive strength or cementation requirements for Type A, but is fissured or subject to vibration; or
- Dry rock that is not stable; or
- Material that is part of a sloped, layered system where the layers dip into the excavation on a slope less steep than four horizontal to one vertical (4H:1V), but only if the material would otherwise be classified as Type B.

Class "C" soil means:

- Cohesive soil with an unconfined compressive strength of 0.5 TSF (48 kPa) or less; or
- Granular soils including gravel, sand, and loamy sand; or
- Submerged soil or soil from which water is freely seeping; or
- Submerged rock that is not stable, or
- Material in a sloped, layered system where the layers dip into the excavation on a slope of four horizontal to one vertical (4H:1V) or steeper.

Cohesive soil means clay (fine-grained soil), or soil with a high clay content, which has cohesive strength. Cohesive soil does not crumble, can be excavated with vertical side slopes, and is plastic when moist. Cohesive soil is hard to break up when dry and exhibits significant cohesion when submerged. Cohesive soils include clayey silt, sandy clay, silty clay, clay, and organic clay.

Competent Person means one who has been trained to identify hazards in the workplace, or working conditions that are unsafe for employees, and who has the authority to have these hazards eliminated or controlled.

Cross Braces mean the horizontal members of a shoring system installed from side to side of the excavation. The cross braces bear against either uprights or wales.

Department means a department at the university that conducts work in excavations.

Dry soil means soil that does not exhibit visible signs of moisture content.

Excavation means any man-made cut, cavity, trench, or depression in an earth surface formed by earth removal.

Faces or Sides mean the vertical or inclined earth surfaces formed as a result of excavation work.

Failure means the movement or damage of a structural member or connection that makes it unable to support loads.

Fissured means a soil material that has a tendency to break along definite planes of fracture with little resistance, or a material that exhibits open cracks, such as tension cracks in an exposed surface.

Granular soil means gravel, sand, or silt (course-grained soil) with little or no clay content. Granular soil has no cohesive strength. Some moist granular soils exhibit apparent cohesion. Granular soil cannot be molded when moist and crumbles easily when dry.

Hazardous Atmosphere means an atmosphere that is explosive, flammable, poisonous, corrosive, oxidizing, irritating, oxygen deficient, toxic, or otherwise harmful that may cause death, illness, or injury.

Ingress and Egress mean "entry" and "exit" respectively and refer to the safe means for employees to enter or exit.

Kick out means the accidental movement or failure of a cross brace.

Layered system means two or more distinctly different soil or rock types arranged in layers. Micaceous seams or weakened planes in rock or shale are considered layered.

Moist soil means a condition in which a soil looks and feels damp. Moist cohesive soil can easily be shaped into a ball and rolled into smaller diameter threads before crumbling. Moist granular soil that contains some cohesive material will exhibit signs of cohesion between particles.

Plastic means a property of a soil, which allows the soil to be deformed or molded without cracking, or appreciable volume change.

Protective System means a method of protecting employees from cave-ins, from material that could fall or roll from an excavation face into an excavation, or from the collapse of adjacent structures. Protective systems include support systems, sloping and benching systems, shield systems, and other systems that provide the necessary protection.

Ramp means an inclined walking or working surface that is used to gain access to one point from another. A ramp may be constructed from earth or from structural materials such as steel or wood.

Registered Professional Engineer means a person who is registered as a professional engineer in Virginia.

Safety Director or designee means the individual at the Environmental Health and Safety department (EHS) that is responsible for developing and implementing this program, conducting unannounced work site inspections, and enforcing departmental compliance with the program.

Saturated soil means a soil in which the voids are filled with water. Saturation does not require flow. Saturation, or near saturation, is necessary for the proper use of instruments such as a pocket penetrometer or shear vane.

Sheeting means the members of a shoring system that retain the earth in position and in turn are supported by other members of the shoring system.

Shield or Shield System means a structure used in an excavation to withstand cave-ins and which will protect employees working within the shield system. Shields can be permanent structures or portable units moved along as work progresses.

Shoring or Shoring System means a structure that is built or put in place to support the sides of an excavation to prevent cave-ins.

Sides See "Faces"

Sloping or Sloping System means sloping the sides of the excavation away from the excavation to protect employees from cave-ins. The required slope will vary with soil type, weather, and surface or near surface loads that may affect the soil in the area of the trench (such as adjacent buildings, vehicles near the edge of the trench and so forth).

Soil classification system means, for the purpose of this subpart, a method of categorizing soil and rock deposits in a hierarchy of Stable Rock, Type A, Type B, and Type C, in decreasing order of stability. The categories are determined based on an analysis of the properties and performance characteristics of the deposits and the characteristics of the deposits and the environmental conditions of exposure.

Stable Rock means natural solid mineral material that can be excavated with vertical sides that will remain intact while exposed.

Structural Ramp means a ramp built of steel or wood, usually used for vehicle access. Ramps made of soil or rock are not considered structural ramps.

Submerged soil means soil, which is underwater or is free seeping.

Support System means a structure such as underpinning, bracing, or shoring, which provides support to an adjacent structure, underground installation, or the sides of an excavation.

Surface Encumbrances include utilities, foundations, streams, water tables, transformer vaults, walkways, bridges, roads, and geologic anomalies.

Surcharge means an excessive vertical load or weight caused by spoil, overburden, vehicles, equipment, or activities that may affect stability.

Tabulated Data means tables and charts approved by a registered professional engineer and used to design and construct a protective system.

Trench means a narrow excavation (in relation to its length) made below the surface of the ground.

Unconfined compressive strength means the load per unit area at which a soil will fail in compression. It can be determined by laboratory testing, or estimated in the field using a pocket penetrometer, by thumb penetration test, and other methods.

Wet soil means soil that contains significantly more moisture than moist soil, but in such a range of values, that cohesive material will slump or begin to flow when vibrated. Granular material that would exhibit cohesive properties when moist will lose those cohesive properties when wet.

Liberty University
Trenching & Excavation Safety Program/Policy
Acknowledgement

I hereby acknowledge receipt of the Liberty University Trenching & Excavation Safety Program/Policy.

I also certify that I have had an opportunity to read and become familiar with the terms and conditions of this Program/Policy and agree to abide by the procedures as set forth. I understand and agree that the University reserves the right to amend, alter, or abolish any or all of the terms of this Program/Policy as circumstances warrant with or without advance notice, and as prescribed by law.

I understand that this Program/Policy now replaces and supersedes any previous verbal or written policies, understandings, or agreements concerning trenching & excavation policies or procedures at Liberty University.

Nothing in this Program/Policy or Acknowledgement is intended to set forth either expressed or implied contractual obligations of the University. I understand that I am an employee at-will with Liberty University; and as such, that we each remain free to terminate the employment relationship with or without advance notice for any reason or for no reason at all.

I understand this Program/Policy will be used in conjunction with any other policies or regulations specific to the performance of my job, if any. These include but are not limited to regulations under the U.S. Department of Labor Occupational Safety and Health Administration (OSHA) as well as the American National Standards Institute (ANSI) standards and other policies under specific Departmental Standard Operating Procedures, and job descriptions.

Signed: _____ Dated: _____

Printed Signature: _____ Position: _____

TRENCHING & EXCAVATION PERMIT

Section 1 - General

Permit Issuer (Supervisor/Manager):	VA811 Ticket #:	
Permit Acceptor:	Date (MM/DD/YY):	
Permit Acceptor Phone #:	Start Work Time:	am / pm (circle one)
Acceptor's Department:	End Work Time:	am / pm (circle one)
Work Location (Bldg./Area):	Weather Conditions:	
Description of Work:		

Section 2 – Excavation Preparation

ITEM	Initial	
	Yes	NA
Mandatory Completion		
1. VA 811 Contacted (Call 811 or 1-800-552-7001) at least 48 hours prior to work starting.		
2. Excavation route pre-marked with white paint before utility survey.		
3. VA 811 Ticket completed and all utilities for excavation route are marked.		
4. Excavation is within 2 feet on either side of utilities (will require competent person on site)		
5. Underground utilities present within 2 feet on either side requiring area to be hand dug.		
6. Personnel will be entering the excavation (requires competent person on site if deeper than 4 feet)		
7. Excavation is between 4 feet or greater (requires completion of Section 5 – Soil Classification)		
8. Excavation is greater than 20 feet (requires EHS review)		

Section 3 – Hazard Control & Elimination

ITEM	Initial	
	Yes	NA
Mandatory Completion		
1. Pre-Job Discussion Conducted (with all workers)		
2. Are workers aware of hazards they may encounter?		
3. Evacuation routes clear (trip hazards removed)		
4. Means of communication established		
5. Barricades in place		
6. Equipment inspections completed (forklift, cranes, etc....)		
7. Adequate precautions taken for heat or cold stress		
8. Emergency Procedures and Contact Numbers provided to competent person and workers		
9. Any adjacent risks (I.E., venting, overhead powerlines, etc.....)		
10. Adjacent Risk or other safety issues:		

	CONTROL MEASURES	Initial	
		Yes	NA
Cave-in: any soil class	<input type="checkbox"/> Trench Box (soil does not have to be classified)		
Cave-in: Assume Class C	<input type="checkbox"/> Slope/Bench 1 ½ H to 1 V (34°)		
Cave-in: all other situations	Contact EHS for special requirements		
Surface Encumbrances	<input type="checkbox"/> Removed <input type="checkbox"/> Supported		
Underground Installations	<input type="checkbox"/> Protected/Supported <input type="checkbox"/> Owner action required		
Access/Egress required at 4 feet	<input type="checkbox"/> Ladder <input type="checkbox"/> Ramp <input type="checkbox"/> Stairs (within 25 feet)		
Vehicular Traffic	<input type="checkbox"/> Barricades <input type="checkbox"/> Signs <input type="checkbox"/> Flagger (person)		
Falling Loads	<input type="checkbox"/> Personnel clear of equipment being loaded		
Hazardous Atmosphere	<input type="checkbox"/> Forced Air Ventilation <input type="checkbox"/> Respiratory Protection <input type="checkbox"/> Continuous air monitoring required, complete section 6 atmospheric testing		
Water Accumulation	<input type="checkbox"/> Pump <input type="checkbox"/> Diversion <input type="checkbox"/> Drainage <input type="checkbox"/> Safety Harness with Lifeline		
Adjacent Structures	<input type="checkbox"/> Shored <input type="checkbox"/> Braced <input type="checkbox"/> Underpinned		
Loose Rock or Soil	<input type="checkbox"/> Spoil Piles at least 2 feet from edge <input type="checkbox"/> Scaling <input type="checkbox"/> Protective Barrier <input type="checkbox"/> Benching <input type="checkbox"/> Restraint Device		
Fall Protection	<input type="checkbox"/> Barricades 6' from edge <input type="checkbox"/> Guardrails on walkways		
Security (overnight)	<input type="checkbox"/> Fencing/barricades <input type="checkbox"/> Holes covered <input type="checkbox"/> Warning Signs <input type="checkbox"/> Lighting		

Section 4 - PPE

<input type="checkbox"/> Ear Plugs	<input type="checkbox"/> Hard Hats	<input type="checkbox"/> Safety Glasses	<input type="checkbox"/> Safety Toed Work Boots	<input type="checkbox"/> Face Shield
<input type="checkbox"/> Specialty Safety Equipment (List):	<input type="checkbox"/> High Vis Vest or Shirt	<input type="checkbox"/> Gloves	<input type="checkbox"/> Googles	

Section 5 – Soil Classification

Mandatory Completion If Excavation is Greater than 4 Feet

- Type A (most stable) Clay, Silty Clay, and Hardpan
- Type B (some instability) Silt, Sandy Loam, Medium Clay, and Unstable Rock
- Type C (least stable) Gravel, Loamy Sand, Soft Clay, and Unstable Rock

Section 6 – Atmospheric Testing (When Applicable)

Retests are required at crew change or when work has stopped for more than one hour. Record results below.

Atmospheric

Testing

OXYGEN	Normal Air	Acceptable Entry Conditions	Initial Test	Retest #1	Retest #2	Retest #3	Retest #4	Retest #5	Retest #6	Retest #7	Retest #8	Retest #9
LEL (flammability)	20.9%	19.5 % - 23.5%										
CO ²	0	0-10%										
H ² S	0	0-35 ppm										
Other:	0	0-10 ppm										
Tester's Name:												
Tester's Name:		Initials of Tester										
		Time of Test										
Type of Monitor:						Serial #:				Date Calibrated:		

Section 7 – Acceptance of Responsibility and Authorization

All conditions have been met and I agree to abide by the conditions identified on this excavation permit.

Permit Acceptor (Print & Sign):

Transfer to:	Time:
Transfer to:	Time:

Mandatory Signature for Workers (print & sign)

(By signing this permit, I fully Understand and accept the risks associated with what is listed above and agree to abide by all safety requirements)

1)	6)	11)
2)	7)	12)
3)	8)	13)
4)	9)	14)
5)	10)	15)

Section 8 – Excavation Inspection Log

	Condition	Hazard Identified	Corrective Action Taken
Inspectors Name:			
Inspector's Signature:			
Date & Time:			
Weather:			
	Condition	Hazard Identified	Corrective Action Taken
Inspector's Name:			
Inspector's Signature:			
Date & Time:			
Weather:			
	Condition	Hazard Identified	Corrective Action Taken
Inspector's Name:			
Inspector's Signature:			
Date & Time:			
Weather:			
	Condition	Hazard Identified	Corrective Action Taken
Inspector's Name:			
Inspector's Signature:			
Date & Time:			
Weather:			
	Condition	Hazard Identified	Corrective Action Taken
Inspector's Name:			
Inspector's Signature:			
Date & Time:			
Weather:			
	Condition	Hazard Identified	Corrective Action Taken
Inspector's Name:			
Inspector's Signature:			
Date & Time:			
Weather:			
	Condition	Hazard Identified	Corrective Action Taken
Inspector's Name:			
Inspector's Signature:			
Date & Time:			
Weather:			
	Condition	Hazard Identified	Corrective Action Taken
Inspector's Name:			
Inspector's Signature:			
Date & Time:			
Weather:			
	Condition	Hazard Identified	Corrective Action Taken
Inspector's Name:			
Inspector's Signature:			
Date & Time:			
Weather:			

Liberty University
Trenching & Excavation Safety Program/Policy

Revision Tracking

Revision Number	Revision Description	Date Originated/ Revised	Policy Author/Reviser	Policy Approvers
	Original	4/10/18	Greg Bennett	
01	Changed to new format, added policy line, total rewrite of policy to include diagrams and other significant information and permit	11/21/22	Greg Bennett	Greg Bennett John Peterson Ronald T. Sloan
02	Minor editing and review	02/14/23	R. Drane	Greg Bennett John Peterson Ronald T. Sloan